

MD2DS Series Factory Sealed Disconnect Switches

No external seals required.

NEC — Non-Fused:

Class I, Division 2, Groups B, C, D
Class II, Division 1 and 2, Groups F, G
Class III
Class I, Zone 1, AEx de IIC, T3, IP66
NEMA 3, 3R, 4, 4X, 12

NEC — Fused:

Class I, Division 2, Groups B, C, D
Class II, Division 1 and 2, Groups F, G
Class III
Class I, Zone 2, Group IIC, T3, IP66
NEMA 3, 3R, 4, 4X, 12

Applications

- Functions as load disconnect switch or as individual motor control switch.

Features

- Factory sealed; no external seals required.
- Available in fused and unfused versions.
- Stainless steel captive cover bolts for easy access and corrosion resistance.
- Standard epoxy powder coating inside and outside delivers exceptional corrosion resistance.
- Insulated, dual-color polymer operating handle clearly indicates the switch being energized. Ergonomically designed handle is made of high-impact polymer material for exceptional ruggedness, durability and corrosion resistance.
- Removable hinged cover allows for ease of installation and maintenance.
- Short circuit withstand rated to 200,000 RMS symmetrical amperes (Class J fusing).
- Short circuit withstand rated to 10,000 RMS symmetrical amperes (unfused).
- Use Class J fusing on fused units (fuses not included).
- Conduit entry is drilled and tapped to 1-1/2". Reducer bushings 1-1/2"-1-1/4" and 1-1/2"-1" provided at no additional cost.
- Stainless steel key-hole mounting feet for easy installation.
- Unit is equipped with defeatable door interlock which allows emergency access when switch is energized.
- Cover can be padlocked closed.
- Operating handle can be locked in the OFF position with provision to lock in the ON position.
- Line side accommodates #8-#4/0 AWG copper wire. Load side unfused accommodates #8-#4/0 AWG copper wire. Load side 30 Amp fused accommodates #14-#6 AWG copper wire. Load side 60 Amp fused accommodates #14-#2 AWG copper wire. Load side 100 Amp fused accommodates #12-#2/0 AWG copper wire.

Standard Materials

- Enclosure: copperfree (4/10 of 1% max.) aluminum
- Operating handle: high impact polymer
- Hardware: stainless steel

Standard Finishes

- Enclosure: epoxy powder coating inside and outside

Options

- One normally opened, one normally closed auxiliary switch, add suffix **-AUX**.

NEC Certifications and Compliances

- UL Standard: UL 98
- UL Listed: E160652



MD2DS Series Factory Sealed Disconnect Switches

No external seals required.

NEC – Non-Fused:
 Class I, Division 2, Groups B, C, D
 Class II, Division 1 and 2, Groups F, G
 Class III
 Class I, Zone 1, AEx de IIC, T3, IP66
 NEMA 3, 3R, 4, 4X, 12

NEC – Fused:
 Class I, Division 2, Groups B, C, D
 Class II, Division 1 and 2, Groups F, G
 Class III
 Class I, Zone 2, Group IIC, T3, IP66
 NEMA 3, 3R, 4, 4X, 12

Type ①	Amps	Max HP at 600 Vac	Dimension A mm (in)	Catalog Number
 Fused <i>(fuses not included)</i>	30	20	489.0 (19.25)	MD2DS3034F
	60	50	489.0 (19.25)	MD2DS6034F
	100	50	489.0 (19.25)	MD2DS1034F
Non-Fused	100	50	581.2 (22.88)	MD2DS1034U

Operating Temperatures

Classification	Fused	Unfused
Class I, Division 2	T3C	T3C
Class I, Zone 1	—	T3
Class I, Zone 2	T3	—
Class II, Division 1 and 2	T6	T6

Dimensions in Millimeters (Inches)

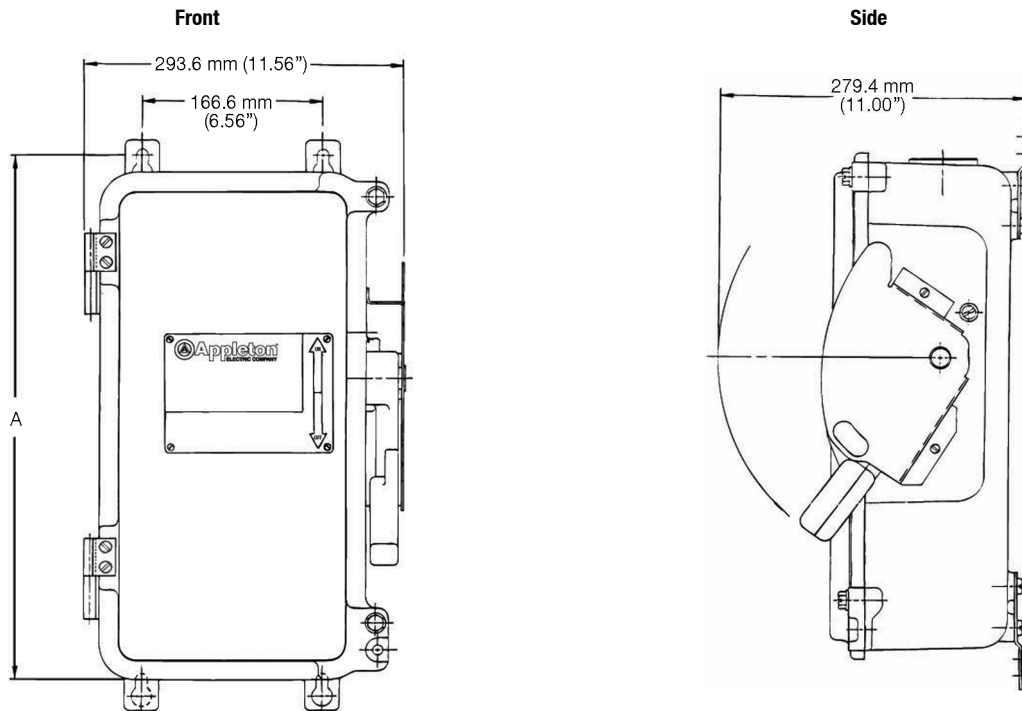

① Fuses not included in fused units. For maximum horsepower please consult fuse manufacturer.